

SmartIFS™

Smart Integrated Fuel Systems for Industrial Gas Turbines

Description

In many turbine fuel control systems, sensor outputs and valve command signals are wired to, and processed within, the main turbine control system. With the introduction of multiple flow paths and higher accuracy gas fuel delivery systems, field wiring complexity has resulted in high installation costs, decreased reliability, and increased vulnerability to incorrect connections and damage in service. The SmartIFS™ approach can greatly simplify the field wiring and system set-up tasks.

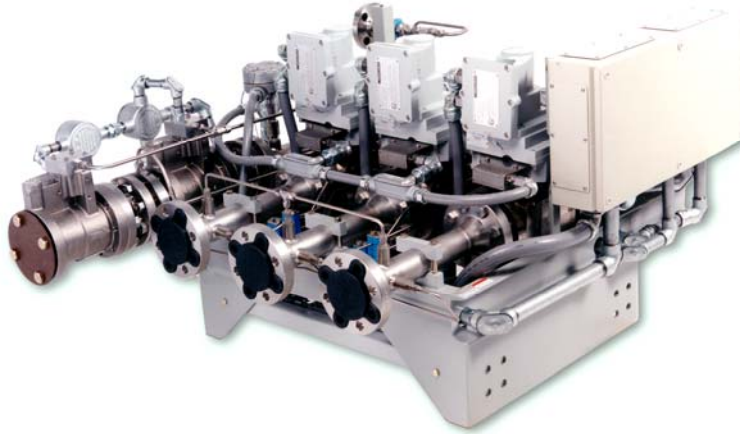

Woodward's SmartIFS integrated fuel system combines fuel valves, sensors, and Fuel Management System (FMS) in a factory-assembled and calibrated system to provide a higher level of performance at a lower system cost. The FMS can perform a range of functions depending on the turbine system. These functions can include: valve positioning, mass flow calculations, network communication, system sequencing, protection, condition monitoring, fault diagnosis, and fault management functions. Simplex or duplex digital communications are available to interface the FMS with the turbine control system and other equipment. Valve and FMS hardware are based on modular design approaches and provide plug-and-play functionality in the field.

The system can be configured to meet a wide range of customer requirements and can be applied to gas turbines from 200 kW to 300 MW output. Multiple valve and FMS options are available.

Features

In the SmartIFS all fuel system components are connected to the Fuel Management System which can:

- Be located on the fuel valve skid or close to the gas turbine enclosure
- Contain valve and sensor characterization data
- Incorporate valve driver (positioner) electronics if not on board the valve
- Serve as a communication portal with the turbine combustion system and other systems
- Facilitate digital communications and advanced diagnostic capabilities
- Execute complex gas mass flow calculation algorithms
- Function as a logic controller for multiple redundant systems

The SmartIFS uses industry-standard networking hardware and protocols and is compatible with multiple third-party digital systems and hardware.

For applications requiring certification to IEC16508 "Functional Safety of Electrical/Electronic/Programmable Electronic Safety Related Systems", a separate Safety Instrumented System may be required for gas turbine protection.

- Exceptional flow metering performance, reliability, and diagnostic capabilities
- Simplifies the turbine control system, leading to faster development and reduced costs
- Plug-and-Play eliminates on-site fuel system calibration
- Reduces commissioning cost and time
- Maximum availability and minimum mean time to repair
- Fleet-wide communication capabilities reduce performance variations and streamline operation/maintenance activities

Benefits

Simplified Turbine Control Results from Integrating with FMS

- Reduced I/O for sensor and actuator interfaces
- Reduced or eliminated diagnostics for the fuel system
- Elimination of flow control calculation and valve characterization burdens

Reduced Installation and Commissioning Costs

- Fully assembled and tested for plug-and-play installation
- No wires to pull, terminate, and check (no loop checks, no ground faults, no mistakes)
- No field calibration procedures for valves or fuel system
- No loading of the gas turbine for fuel system calibration
- Reduced fuel usage for turbine commissioning
- Single point fuel system accountability
- Troubleshooting reduced through improved diagnostics

Improved Turbine Operations and Maintenance

- Improved fuel system accuracy and response characteristics
- Repeatable and consistent engine starting and operation
- Reduced maintenance
- Advanced diagnostics using smart sensors and valves
- Potential reductions in fuel system pressure losses

Scalable Modular Design for Reduced Costs

The *Smart*FMS can be scaled to address multiple applications and configurations, including:

- Simplex control systems
- Duplex or triplex control systems
- 1 to 5 independently controlled fuel paths per gas turbine
- Base or Dry Low Emission gas turbine versions
- A common interface to the turbine combustion system for all fuel systems

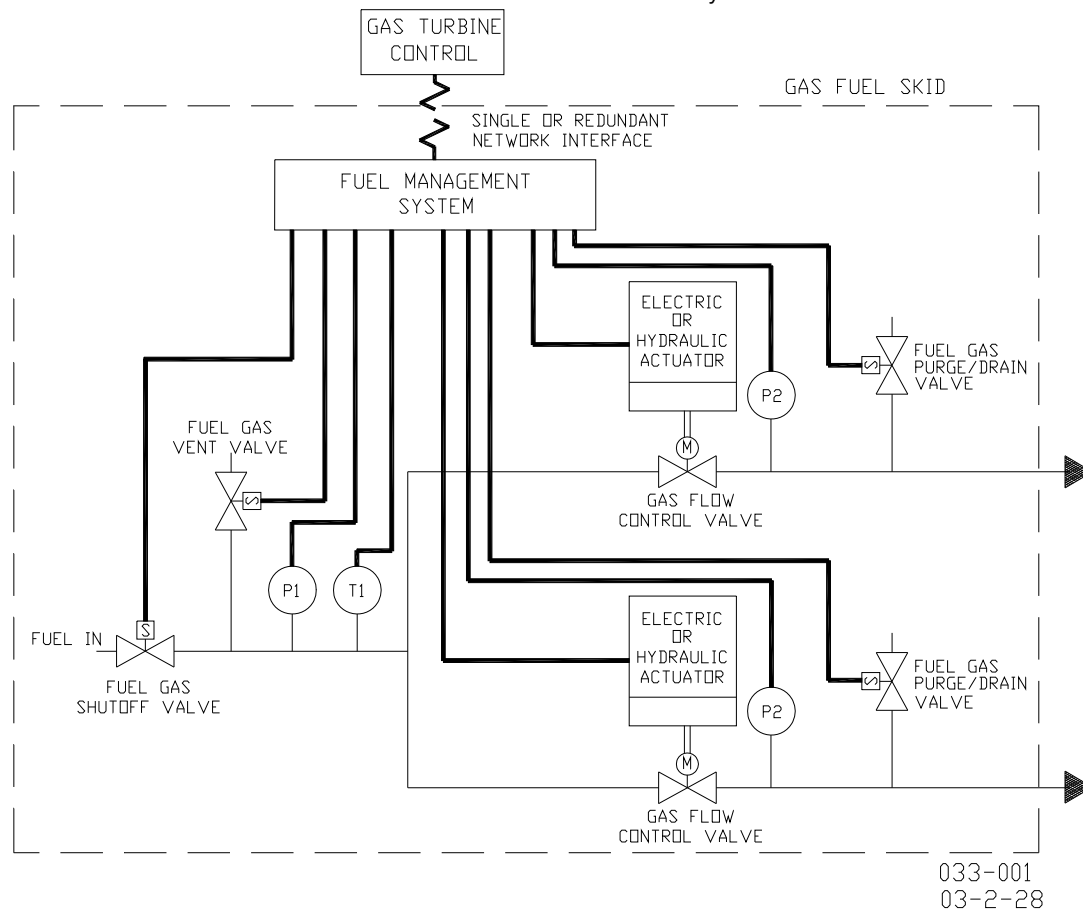

Example of a Smart Integrated Fuel System—2 Flow Path Version



PO Box 1519, Fort Collins CO, USA 80522-1519
 1000 East Drake Road, Fort Collins CO 80525
 Tel.: +1 (970) 482-5811 • Fax: +1 (970) 498-3058
www.woodward.com

Distributors & Service

Woodward has an international network of distributors and service facilities. For your nearest representative, call the Fort Collins plant or see the Worldwide Directory on our website.

This document is distributed for informational purposes only. It is not to be construed as creating or becoming part of any Woodward Governor Company contractual or warranty obligation unless expressly stated in a written sales contract.

© Woodward 2003, All Rights Reserved

For more information contact:

2008/8/Fort Collins